

| REVISIONS | | | |
|-----------|--------------------------------|-----------|---------|
| REV. | DESCRIPTION | DATE | APPROV. |
| - | INITIAL RELEASE | 01 MAR 06 | MJVK |
| A | CHANGED PART -761 IN ASSY -756 | 6/12/2006 | MJVK |
| B | COMPLETE PART REDESIGN | 5/31/2007 | MJVK |

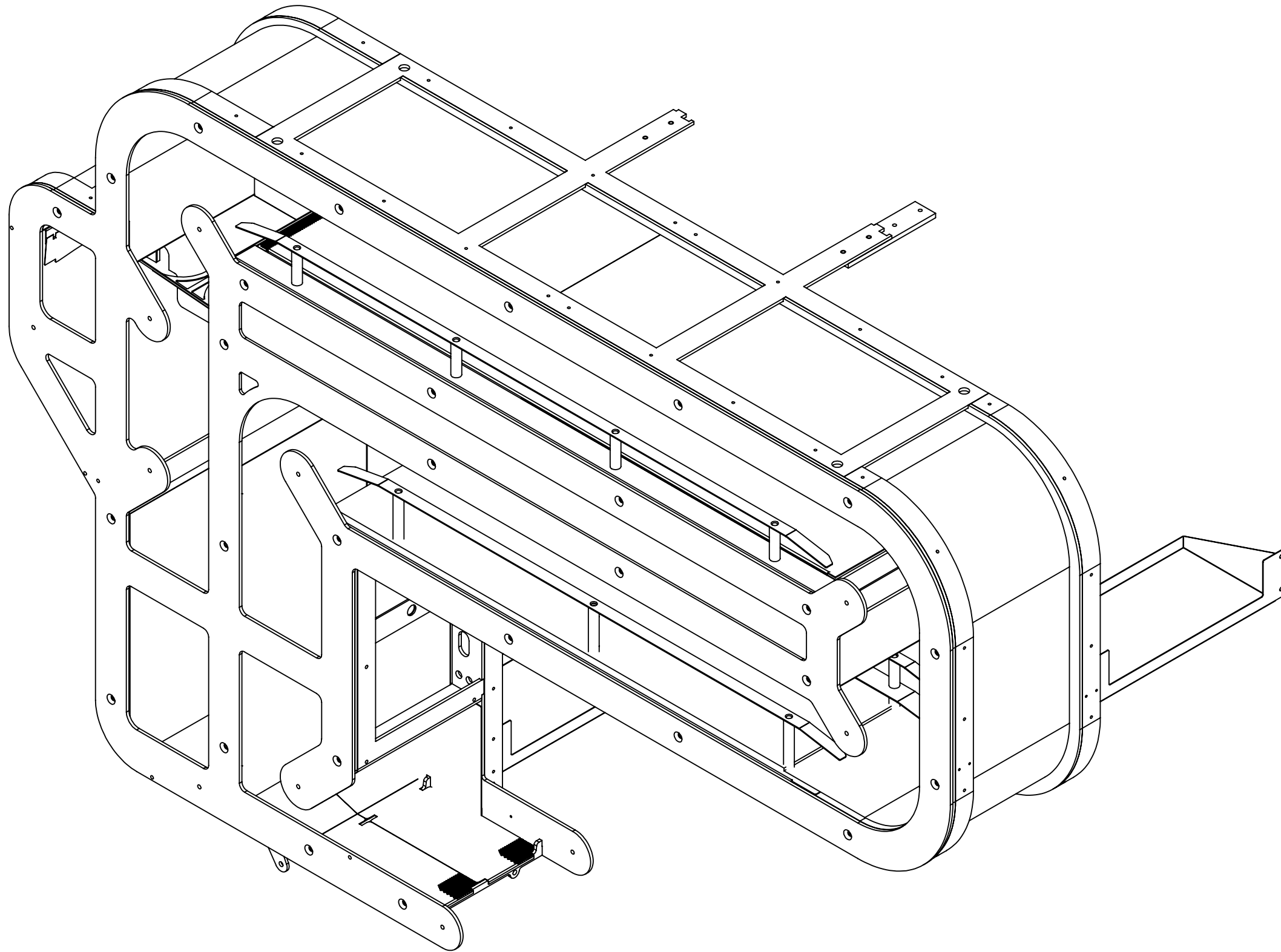

*(1) RIGHT HAND SHOWN PLUS
(1) LEFT HAND OPPOSITE*

| ITEM NO. | PART NUMBER | REV. | DESCRIPTION | Qty. |
|----------|----------------|------|--------------------------|------|
| 1 | MGM-010306-300 | B | SIDE, OVEN, ASSY. | 1 |
| 2 | MGM-010306-751 | C | LONG OVEN RAIL ASSY. | 1 |
| 3 | MGM-010306-752 | D | SHORT OVEN RAIL ASSY. | 1 |
| 4 | MGM-010306-753 | B | OVEN ELEMENT ASSY. | 1 |
| 5 | MGM-010306-754 | B | SS SHEET A ASSY | 1 |
| 6 | MGM-010306-755 | C | SS SHEET B ASSY. | 1 |
| 7 | MGM-010306-756 | C | SS SHEET C ASSY. | 1 |
| 8 | MGM-010306-757 | B | SS SHEET D ASSY. | 1 |
| 9 | MGM-010306-758 | C | LONG OVEN RAIL ASSY. | 1 |
| 10 | MGM-010306-759 | D | SHORT OVEN RAIL ASSY. | 1 |
| 11 | MGM-010306-760 | E | SS SHEET PART A | 1 |
| 12 | MGM-010306-761 | D | SS SHEET PART M | 1 |
| 13 | MGM-010306-763 | C | SS SHEET PART C | 1 |
| 14 | MGM-010306-765 | C | SS SHEET PART E | 1 |
| 15 | MGM-010306-766 | C | SS SHEET PART F | 1 |
| 16 | MGM-010306-773 | - | OVEN COPPER TRIM | 1 |
| 17 | MGM-010306-774 | - | SMALL OVEN TRIM | 1 |
| 18 | MGM-010306-785 | - | ELEMENT COVER | 2 |
| 19 | MGM-010306-788 | - | EXIT: PAN STABILIZER | 1 |
| 20 | MGM-010306-793 | B | OVEN INSULATION SHIELD C | 1 |
| 21 | MGM-010306-794 | B | OVEN INSULATION SHIELD C | 1 |
| 22 | WBC-406 | - | | 1 |
| 23 | Insulation | - | N/A | 1 |

| | | | | | |
|--|--|--|-------------------------------------|---|--|
| | <small>UNLESS OTHERWISE SPECIFIED ALL DIMENSIONS ARE IN INCHES TOLERANCES ARE:</small> <small>FRACTIONS DECIMALS ANGLES</small> <small>±1/64 .005 ±.02 ±1/2°</small> <small>XXX ±.010</small> | MATERIAL | N/A | WILKINSON BAKING BREAD MACHINE OVEN SS SHEET ASSY. | |
| | <small>DRAWN</small> J. KNIGHT | <small>DATE</small> 01 MAR 06 | FINISH | | |
| <small>THIS DRAWING IS THE PROPERTY OF WILKINSON BAKING. IT IS SUPPLIED FOR REFERENCE ONLY AND IS NOT TO BE USED FOR ANY OTHER PURPOSE WITHOUT WRITTEN PERMISSION FROM WILKINSON BAKING COMPANY.</small> | <small>CHECKED</small> <small>DATE</small> | <small>WEIGHT (APPROX.)</small> 655.92 LBS. | <small>SIZE</small> B | <small>CAD FILE</small> | <small>DWG NO.</small> MGM-010306-750 |
| <small>APPROV.</small> | <small>DATE</small> | <small>SCALE</small> 1:24 | <small>DO NOT SCALE DRAWING</small> | <small>SHEET</small> 1 | <small>OF</small> 4 |

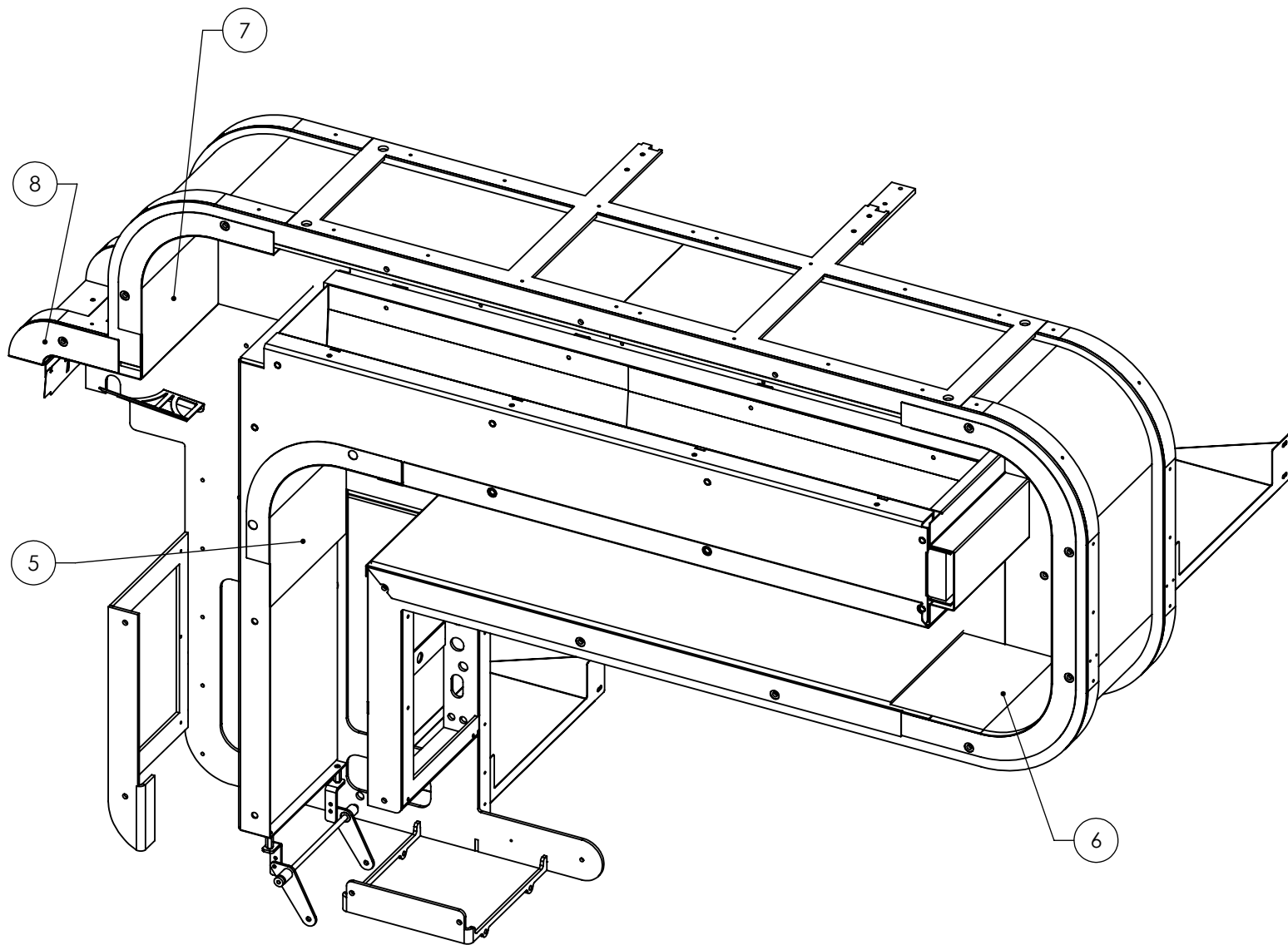

INSERT #11 (-755), #12 (-756), #15 (-754), #19 (-782), AND #26 (-757) INTO #1 (-300) FIRST.

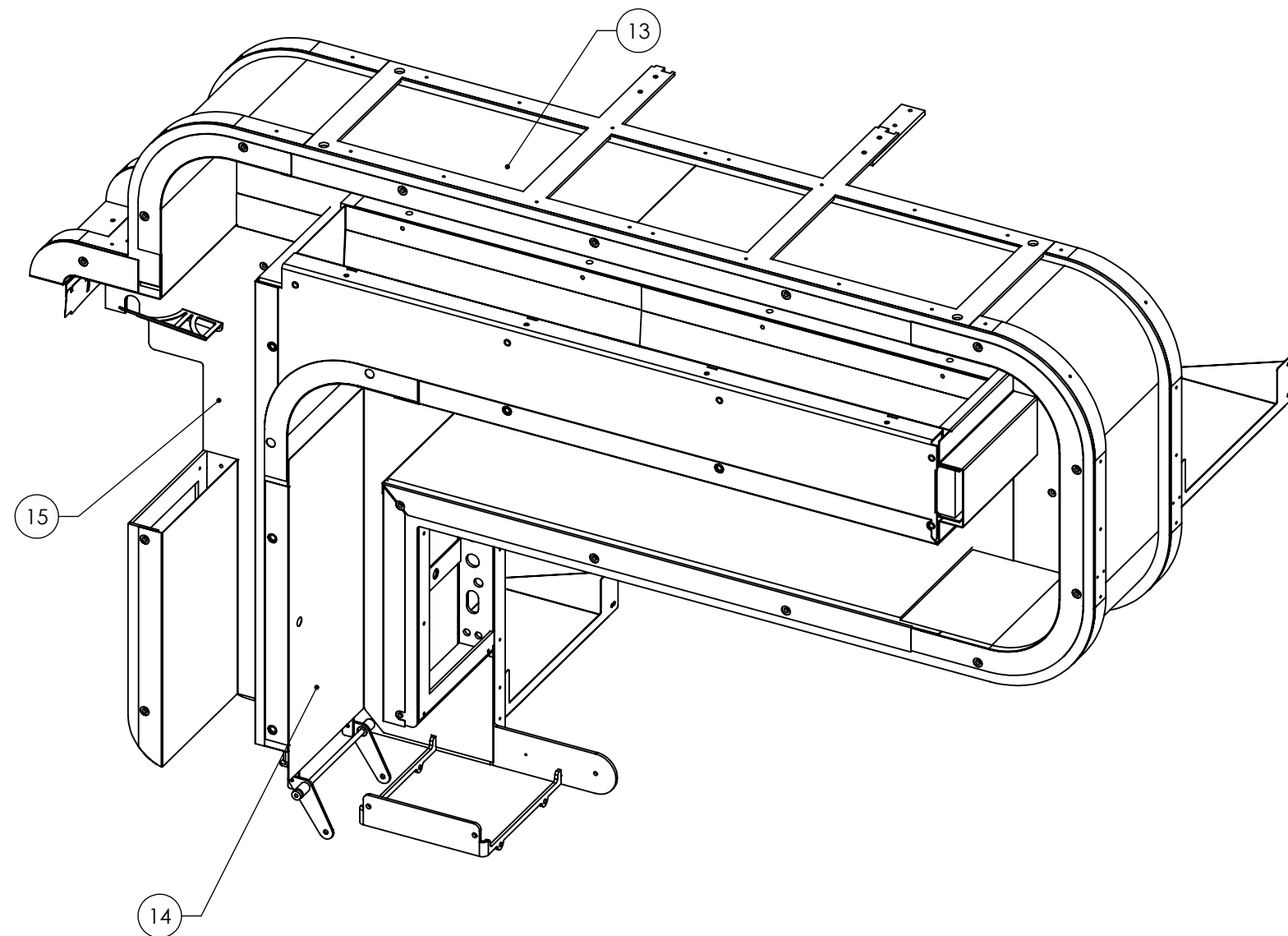

INSERT #10 (-763), #13 (-765), AND #14 (-766) NEXT. THEY WILL OVERLAP #11 (-755), #12 (-756), AND #15 (-754).

| | | | | | | | |
|--|---|-----------|---------|----------|---|---|---------------------------------|
| | UNLESS OTHERWISE SPECIFIED ALL DIMENSIONS ARE IN INCHES TOLERANCES ARE: | | | MATERIAL | N/A | WILKINSON BAKING BREAD MACHINE OVEN SS SHEET ASSY. | |
| | FRACTIONS | DECIMALS | ANGLES | FINISH | NONE | | |
| | ±1/64 | .XX ±.02 | ±1/2° | DATE | 01 MAR 06 | WEIGHT (APPROX.) | 655.92 LBS. |
| | DATE | 01 MAR 06 | SCALE | 1:32 | DO NOT SCALE DRAWING | SHEET | 2 OF 4 |
| <small>THIS DRAWING IS THE PROPERTY OF WILKINSON BAKING. IT IS SUPPLIED FOR REFERENCE ONLY AND IS NOT TO BE USED FOR ANY OTHER PURPOSE WITHOUT WRITTEN PERMISSION FROM WILKINSON BAKING COMPANY.</small> | CHECKED | DATE | APPROV. | DATE | SIZE B DWG NO. MGM-010306-750 REV C | SCALE 1:32 DO NOT SCALE DRAWING SHEET 2 OF 4 | WEIGHT (APPROX.) 655.92 LBS. |

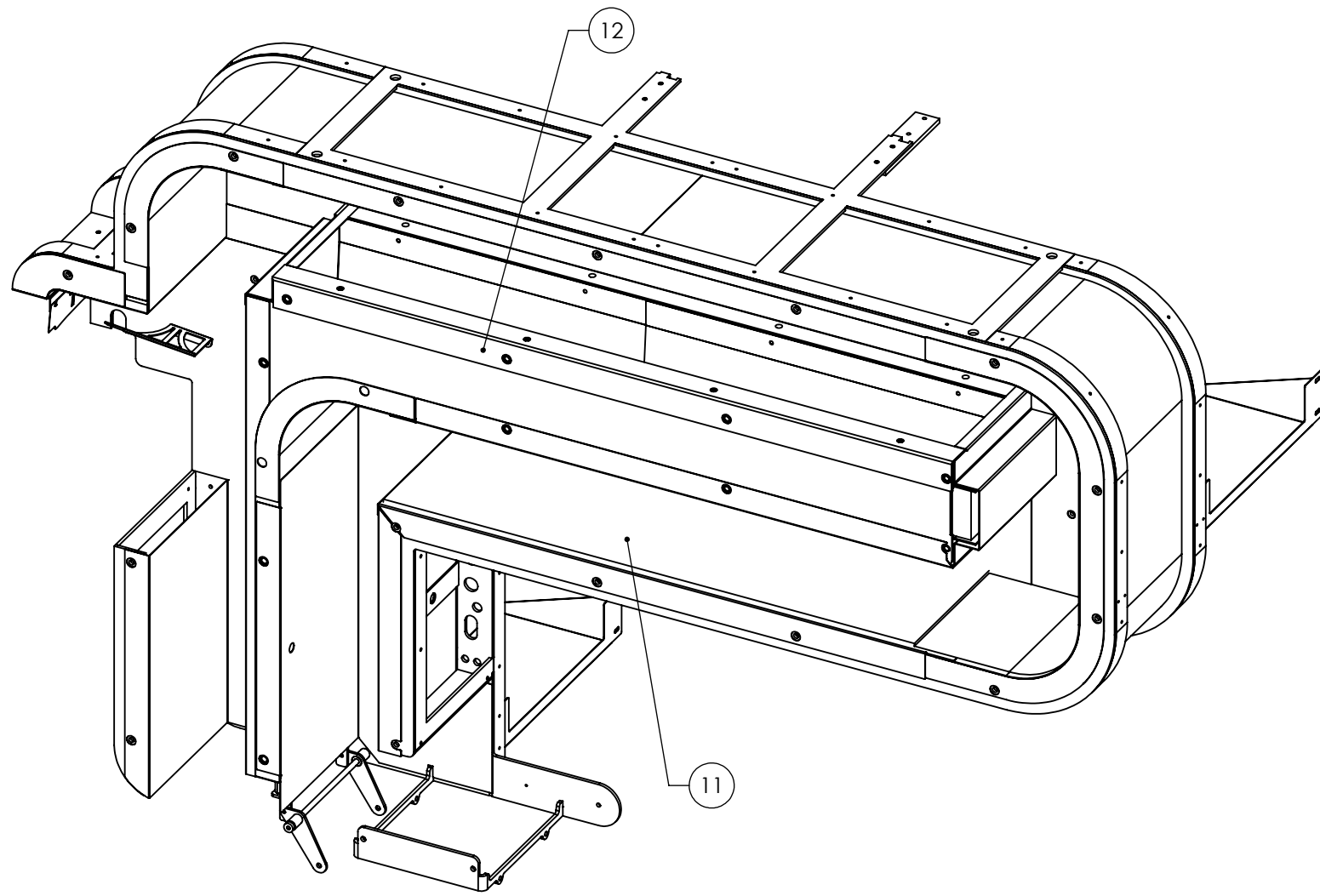

*INSERT #9 (-760), AND #20 (-761).
THEY WILL OVER LAP THE OTHER INSERTED SHEET PARTS.*

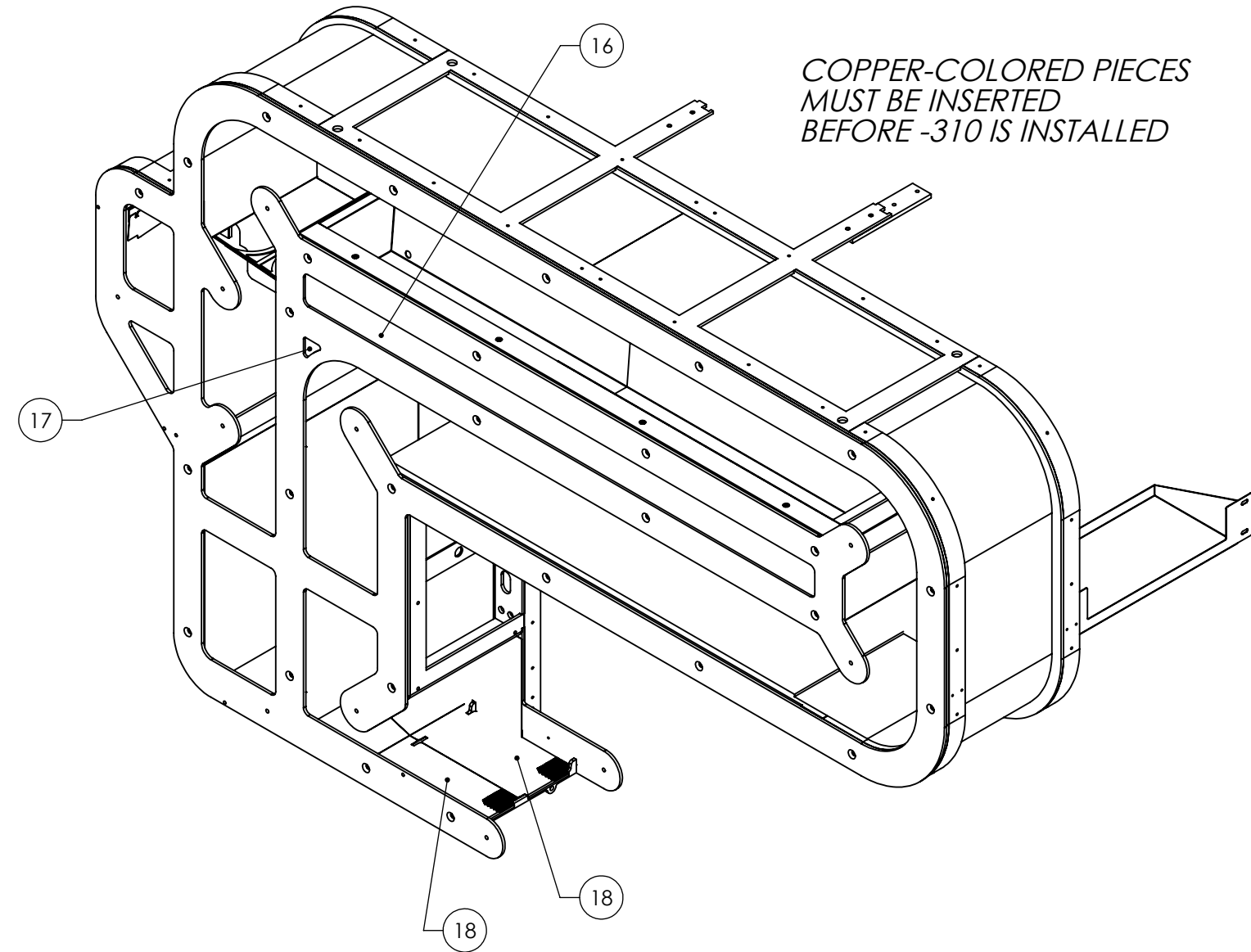

| | | | | | | |
|--|--|---|--|------------------------------|-------------------------------------|---|
| | <small>UNLESS OTHERWISE SPECIFIED ALL DIMENSIONS ARE IN INCHES TOLERANCES ARE:</small> | | | MATERIAL | N/A | WILKINSON BAKING BREAD MACHINE OVEN SS SHEET ASSY. |
| | <small>FRACTIONS</small> 1/164 | <small>DECIMALS</small> .XX ±.02 .XXX ±.010 | <small>ANGLES</small> ±1/2° | FINISH | NONE | |
| <small>DRAWN</small> J. KNIGHT | <small>DATE</small> 01 MAR 06 | <small>APPROV.</small> | <small>WEIGHT (APPROX.)</small> 655.92 LBS. | <small>SCALE</small> 1:24 | <small>DO NOT SCALE DRAWING</small> | <small>SIZE</small> B |
| <small>THIS DRAWING IS THE PROPERTY OF WILKINSON BAKING. IT IS SUPPLIED FOR REFERENCE ONLY AND IS NOT TO BE USED FOR ANY OTHER PURPOSE WITHOUT WRITTEN PERMISSION FROM WILKINSON BAKING COMPANY.</small> | | | <small>DWG NO.</small> MGM-010306-750 | <small>REV</small> C | <small>SHEET</small> 3 | <small>OF</small> 4 |

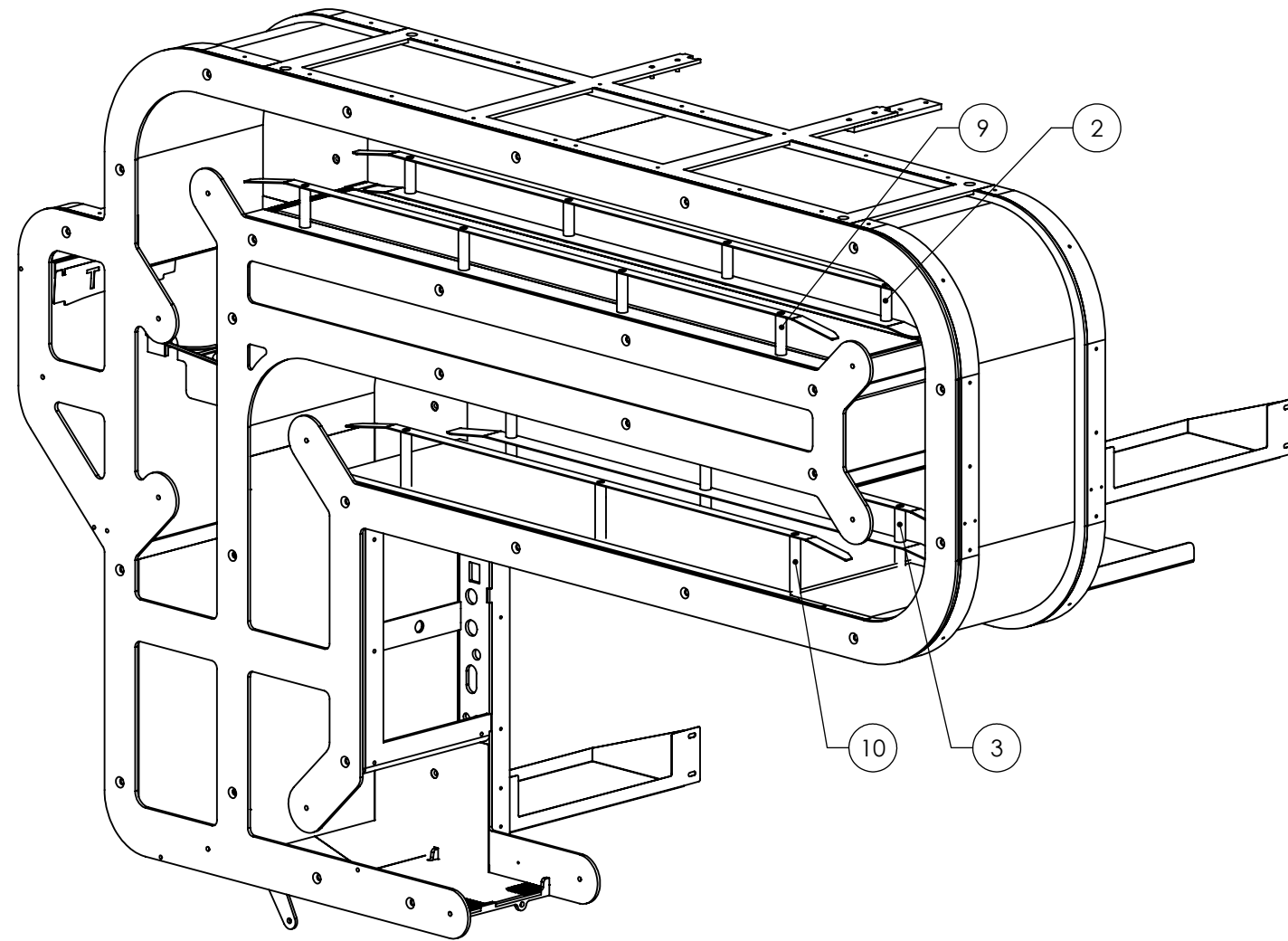

| | | | | | | |
|---|--|-------------------|------------------|----------------------|---|---------------------------------------|
|  | UNLESS OTHERWISE SPECIFIED ALL DIMENSIONS ARE IN INCHES TOLERANCES ARE: FRACTIONS DECIMALS ANGLES ±1/64 .XX ±.02 ±1/2° .XXX ±.010 | | MATERIAL | N/A | WILKINSON BAKING BREAD MACHINE OVEN SS SHEET ASSY. | |
| | DRAWN J. KNIGHT | DATE 01 MAR 06 | FINISH | NONE | | |
| | CHECKED DATE | DATE | WEIGHT (APPROX.) | 655.92 LBS. | SIZE B | CAD FILE DWG NO. MGM-010306-750 |
| | APPROV. DATE | DATE | SCALE 1:24 | DO NOT SCALE DRAWING | SHEET 4 | OF 4 |